

USER MANUAL

SOLAR CHARGE CONTROLLER

100A/120A/150A

Table of Contents

1. Precautions	1
1.1 Safety Precautions	1
1.2 Logo Description	2
1.3 Safety Instructions	2
2. Inspection Of Equipment Opening Sealing	3
2.1 Accessories	3
2.2 Check If It Is Damaged During Transportation	3
2.3 Confirm Charging Controller	3
3. Controller Installation	4
3.1 Selection Of Installation Position	4
3.2 Safety Distance	4
3.3 Environment Condition	4
4. MPPT Controller Connection	5
4.1 Combination of Solar Charging System	5
4.2 Wiring Steps	5
4.3 Battery Connection	6
4.4 Photovoltaic Component Connection	6
4.5 Power Trial Run	7
5. Operating Instruction	9
5.1 Panel Part Specification	9
5.2 Communication Terminal	9
5.3 Main Interface Description	10
5.4 Check Main Interface	10
5.5 Main Menu	11
5.6 Language Setting	13
5.7 Time & Date	13
5.8 Sounds Setting	14
5.9 Records Query	14
5.10 Delete Record	15
5.11 System Information	15
5.12 Communication Setting	16
5.13 Parameter Settings	16
5.14 Battery type setting	17
5.15 Battery Rated Voltage	17
5.16 Charge Voltage Settings	18
5.17 Charge Current Settings	18
5.18 Restore factory settings	19
6. Technical Parameter	20
7. Fault Elimination	24
8. Maintenance And Cleaning	25
9. Quality Assurance	26

1. Precautions

This manual describes the operation related to the MPPT solar charge controller.

1.1 Effectiveness

This manual is applicable to all models of MPPT solar charge controller of our company.



1.2 Target groups

This manual applies to installers and operators



1.3 Before installing and operating the controller, please read this manual and keep it carefully.

1.4 Symbol Description

The followings are descriptions of the type of logo that appears in this manual:



	Warning ! If not avoided, it may cause a machine stoppage or accident
	Danger ! If not avoided, it may cause a machine stoppage or accident
	Attention ! In order to operate the equipment effectively, please read the equipment operation instructions carefully

1.1 Safety Precautions

	Warning ! <ul style="list-style-type: none"> • Input voltage range of this controller is large. It will lead to personal injuries if it is not operated cautiously; • All work on the charge controller must be carried out by a technician; • The device can not be operated by children or people lack of body sensibility and those who are poor in their minds, lack of experience and knowledge of the operation; • Keep away from children and make sure children can not touch.
	Warning ! High heat housing parts. <ul style="list-style-type: none"> • Please install in a well ventilated environment.
	Warning ! Radiation is harmful to healthy. <ul style="list-style-type: none"> • Do not stay near the solar charger controller within 20 cm for a long time.



1.2 Logo Description

This section shows all instructions displayed on all device labels.

Logo	Instruction
	Risk of electric shock ; The energy stored in the capacitor will remain after five minutes of disconnection, and after the break, do not touch internal components within 5 minutes.
	There is not self-repair parts inside the machine, so do not try to remove the cover; only professional personnel can operate and maintain the equipment; please use the insulation tool to drop risk of harm during operation.
	Beware of high heat shell ; The solar charger controller becomes hot during operation. Avoid contact during operation; It is forbidden to place any items on the equipment and to block the fan vents.

1.3 Safety Instructions

When using this equipment, please keep the following information in mind so as to avoid fire, lightning or other personal injuries :

	Warning ! Make sure that the input DC voltage = the specified maximum voltage, the voltage is too high may cause permanent, Damage to the solar controller, the above situation will not be included in the warranty period. This chapter contains important safety and operating instructions. Read and keep this manual for future use.
	Warning ! The technician if you want to maintain or clean the solar controller or connect to the circuit, must first follow the relevant steps.

- Before using the solar charge controller, read all instructions and warning signs on the solar charge controller and the corresponding sections of this manual;
- Please use the parts recommended or sold by our company;
- Make sure the existing lines are in good conditions and wire size are suitable in order to avoid the risk of fire and electric shock; do not operate when solar controller is damaged and wiring is qualified;
- Do not disassemble the solar charge controller by yourself. Attempts to repair a solar charge controller may result in further risk of damage or accident and loss of quality of warranty;
- Keep away from flammable and explosive materials in order to avoid fire;
- The installation location should be kept away from moisture or corrosive substances;
- In order to reduce the rate of short circuit, the technician must use the insulation tool to operate the equipment.

2. Inspection Of Equipment Opening Sealing

2.1 Accessories

Item	Quantity	Remark
Controller	1	
Temperature sensor	1	
Operation Manual	1	

Please contact distributor when finding missing parts.

2.2 Check If It Is Damaged During Transportation

After receiving device, please do not rush to sign at first, please open the sealing and check whether there is damage or crack appearance, if there is, please refuse to sign and contact distributor.



2.3 Confirm Charging Controller

The label of charging controller is pasted on the side of case, If you find the device does not matched the one you purchase, please contact distributor.

3. Controller Installation

3.1 Selection Of Installation Position

Installation must be done by professional technician.

	<p>Danger !</p> <p>The case of charging controller will become hot during operation.</p> <ul style="list-style-type: none"> • Do not install on the flammable building material; • Do not install nearby the highly flammable material; • Do not install in the potentially dangerous explosion area; • Do not install the charging controller in direct sunlight in order to avoid the loss caused by overheating.
	<p>Warning !</p> <p>The controller has built-in thermal storage module components.</p> <ul style="list-style-type: none"> • Do not touch the controller while it is working and the case is open.

3.2 Safety Distance

Observe the following safety gap, make sure other equipment or object are not in this range and make sure there is enough room for heat dissipation.

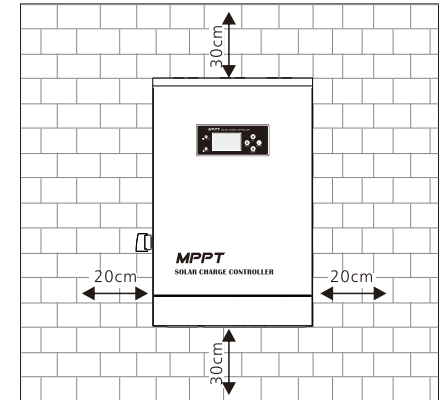

3.3 Environment Condition

- Install on solid surface;
- Installation position must be approachable anytime;
- Installation position can be removed anytime;
- Only temperature of $-20^{\circ}\text{C}\sim 50^{\circ}\text{C}$ can confirm the best working environment;
- Do not install the charging controller in direct sunlight in order to avoid power damage caused by overheating.



Remember that this inverter is heavy! Please be careful when lifting out from the package.

The inverter is suitable for mounting on concrete or other non-combustible surface only.

Step 1

- Please use the mounting back plate as a template to drill 4 holes (diameter 8 mm, depth 60 mm).
- Use the random bolts in the accessory box to firmly fix the mounting back plate to the wall.(See Pic 1)

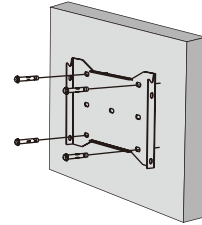

Pic 1

Step 2

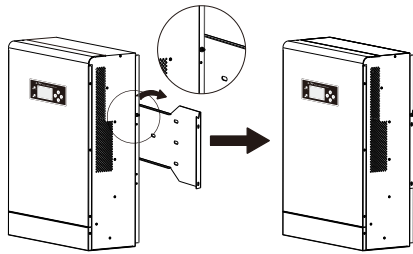

Pic 2

- Fix the bolts on the inverter. Do not tighten the screws.
- Two persons are required to hold the inverter and fix the inverter on the installation backplane. (See Pic 2)

Step 3

- Fix the inverter with the M5 screws in the accessories. (See Pic 3)

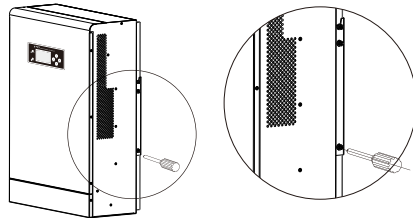

Pic 3

4. MPPT Controller Connection

4.1 Combination of Solar Charging System

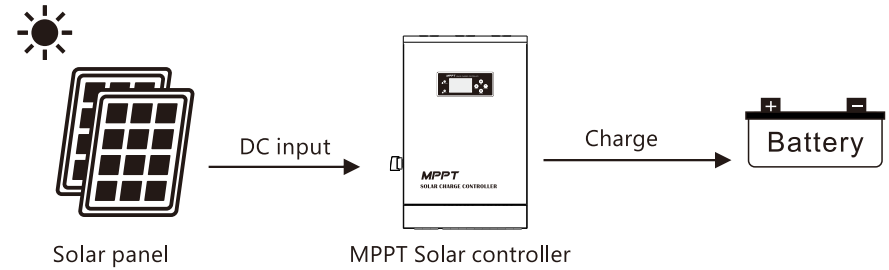

4.2 Wiring Steps

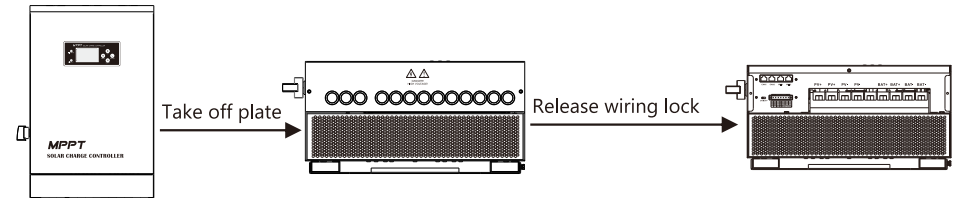

Specifications of cable and miniature circuit breaker:

Model	100A	120A	150A
Cable (copper)	25mm ²	25mm ²	30mm ²
Circuit Breaker	150A	150A	200A

4.3 Battery Connection



Warning: Short circuit of battery's positive and negative terminals and wires of positive and negative electrode will lead to fire or risk of explosion. Please operate carefully.

240V System

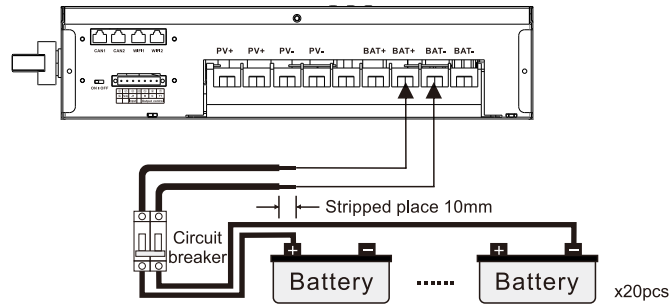

Attention: The operation of connecting batteries must be done under the situation that the circuit breaker is disconnected.

4.4 Photovoltaic Component Connection

Controller can match 196V, 216V, 240V off-grid system solar component, it's also can use a grid-connected component that open-circuit voltage does not exceed the specified maximum input voltage. The solar component voltage in the system must be not lower than the system voltage.

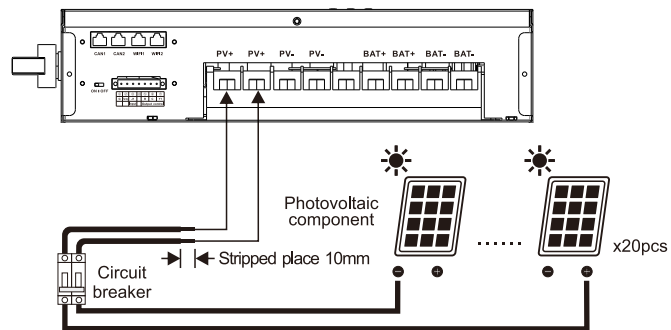

Attention: The operation of connecting photovoltaic component must be done under the situation that the circuit breaker is disconnected.

4.5 Power Trial Run

Attention: please make sure that all the positive and negative poles of the DC connection are connected correctly before the trial run

Proceed as the followings :

1. Make sure that the positive and negative terminals of the cable are fully connected and measure if the open circuit voltage of the PV module is within the operating range of the controller;
2. Turn on the circuit breaker connected with controller and battery;
3. Turn on the circuit breaker connected with controller and solar panel;
4. Then the controller starts to enter the self-test mode; if system conditions are correct, the controller automatically enter the working mode; If the system conditions are not correct, the controller will have fault indications, refer to the chapter of fault elimination.
5. Battery type: the factory setting defaults lead-acid maintenance-free battery, refer to the battery type settings.

5. Operating Instruction

5.1 Panel Part Specification

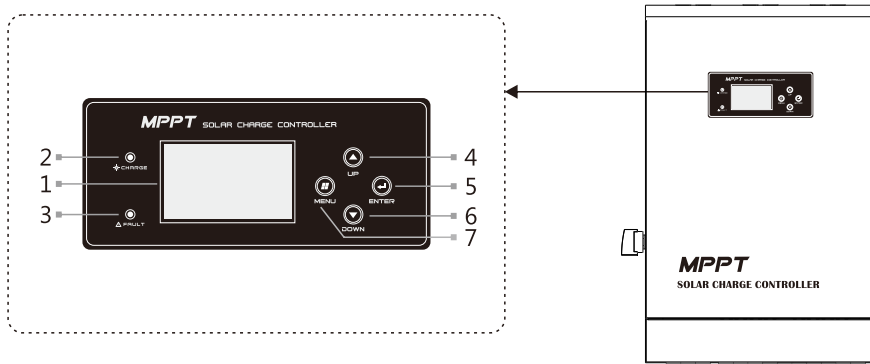

No	Name	No	Name
1	LCD Display	5	Enter
2	Charging Indicator Light	6	Down
3	Fault Indicator Light	7	Function Menu
4	Up		

5.2 Communication Terminal

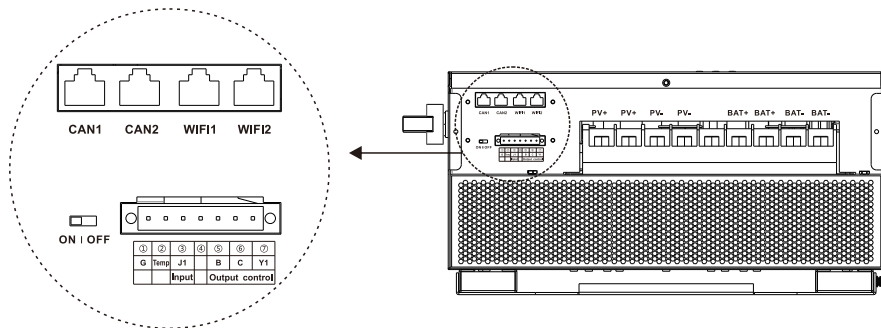

5.3 Main Interface Description

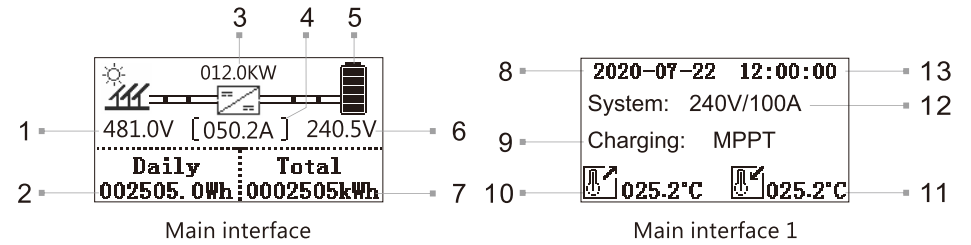

No	Description	No	Description
1	PV module voltage	8	Date
2	Daily power generation(charging volume)	9	Charging state:maximum power tracking, floating charge,stop ,charging.
3	Charging power	10	External temperature
4	Charging current	11	Internal temperature
5	Battery capacity indication	12	Battery type/System voltage current level
6	Battery voltage	13	Real time
7	Total power generation(charging volume)		

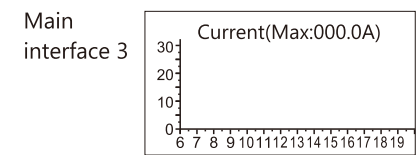
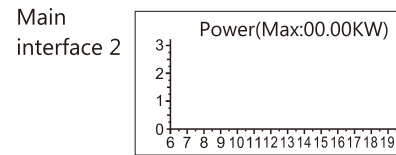

Name	Power Curve(Max:00.00KW)	Name	Current Curve(Max:000.0A)
X	Time (6:00-20:00)	X	Time (6:00-20:00)
Y	Power (Proportion:1:1000)	Y	Current (Proportion:1:1)
Max:00.00KW(Record the highest charging power value of the day)		Max:000.0A(Record the highest charging current value of the day)	

5.4 Check Main Interface

In the default main interface,press DOWN or UP to look through other interfaces.

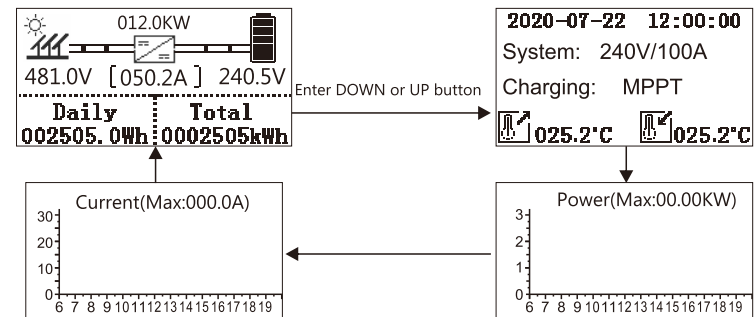

5.5 Main Menu

In the default main interface, press MENU to enter the main menu and press DOWN or UP to view the submenu.

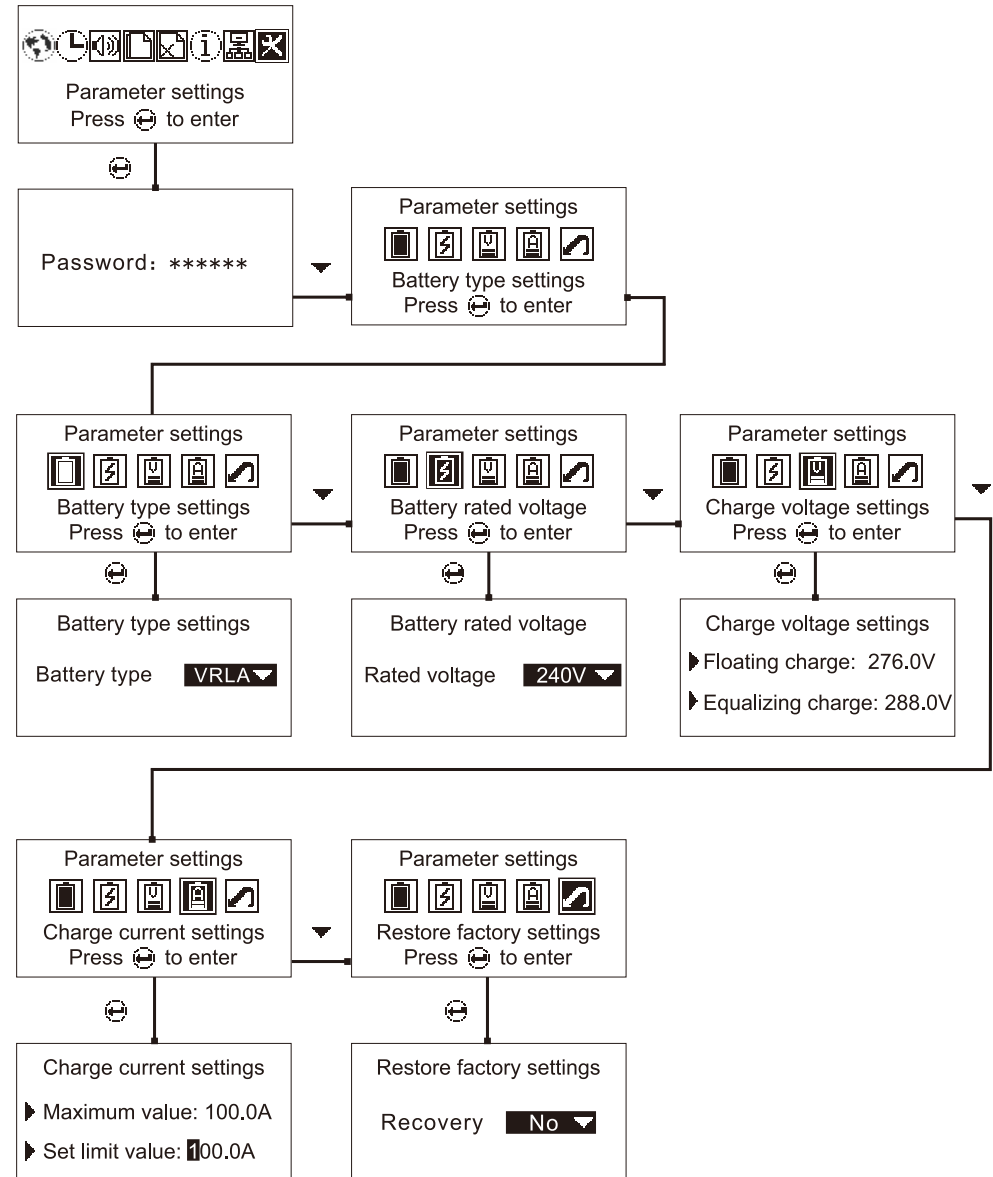
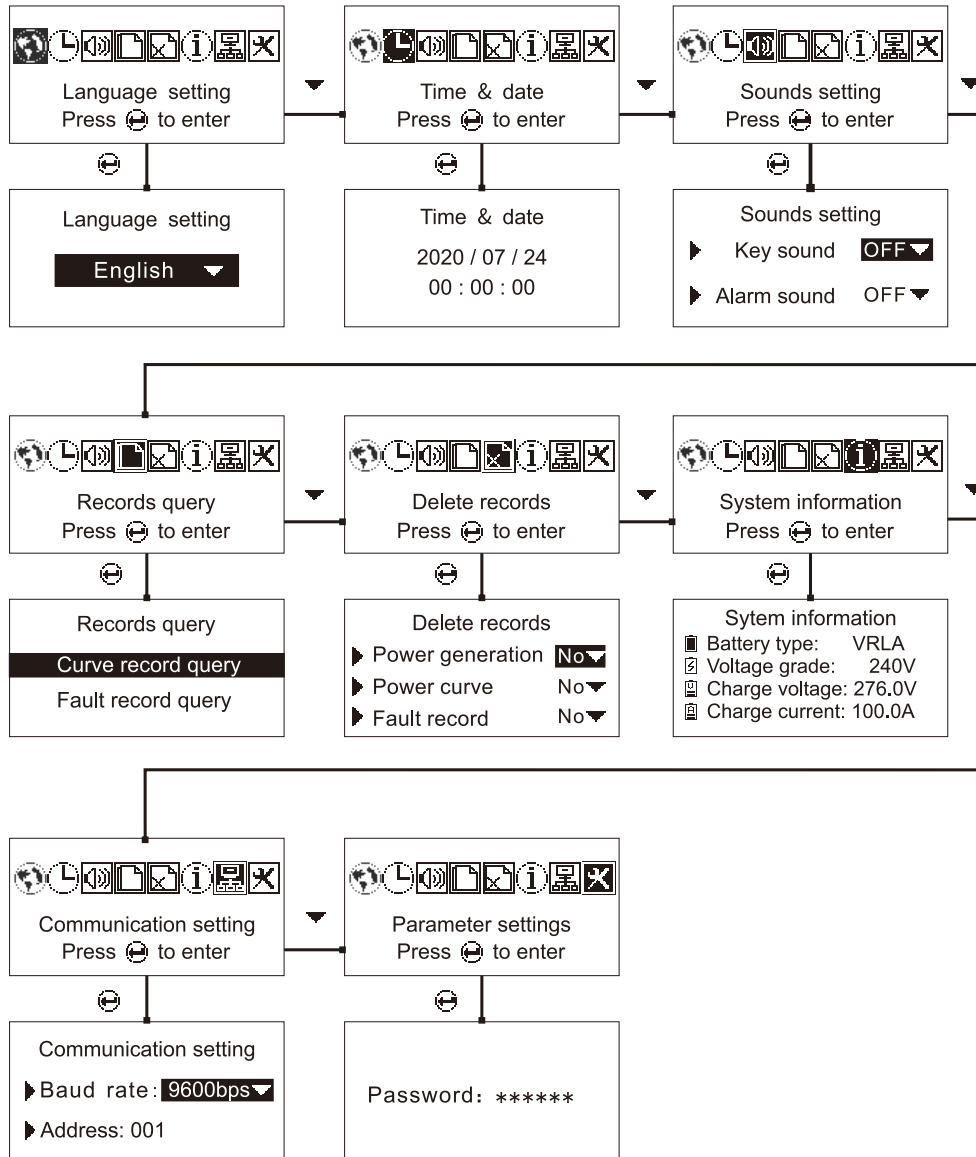

5.6 Language Setting

In the default main interface, press MENU to enter the main menu, press ENTER to enter the language setting, press UP to select the language and then press the ENTER key to confirm and press MENU to return to the main interface after hearing continuous indicative sound.

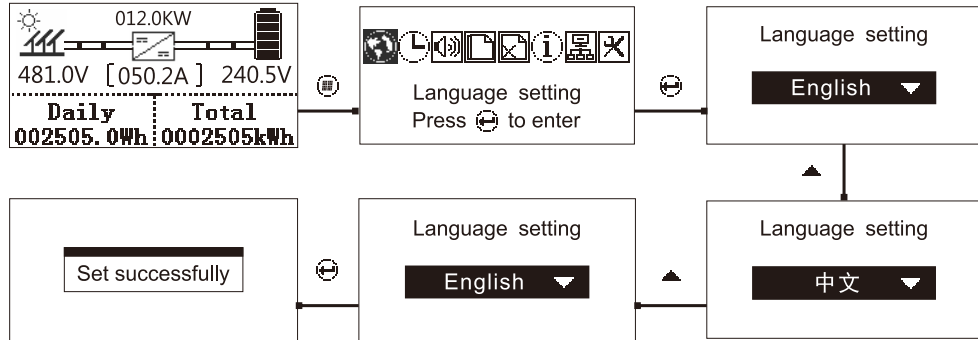

5.7 Time & Date

In the default main interface, press MENU to enter the main menu, press DOWN to select the time setting, press ENTER to enter time setting, press DOWN to move the cursor, press UP to modify the value, press ENTER after confirming the modified value and press MENU to return to the main interface after hearing continuous indicative sound.

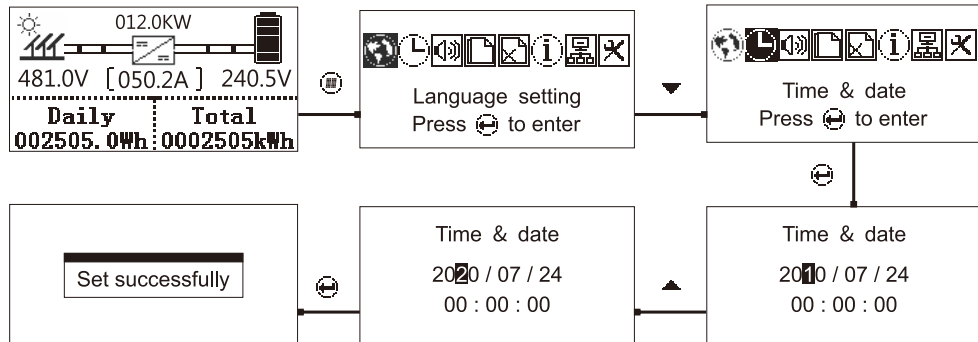

5.8 Sounds Setting

In the default main interface, press MENU to enter the main menu, press DOWN to select the sound setting, press ENTER to enter the sound setting, press UP to select the whether the key sound is on or off, press DOWN to move the cursor to select whether the alarm sound is on or off, press ENTER to confirm and press MENU to return to the main interface after hearing continuous indicative sound.

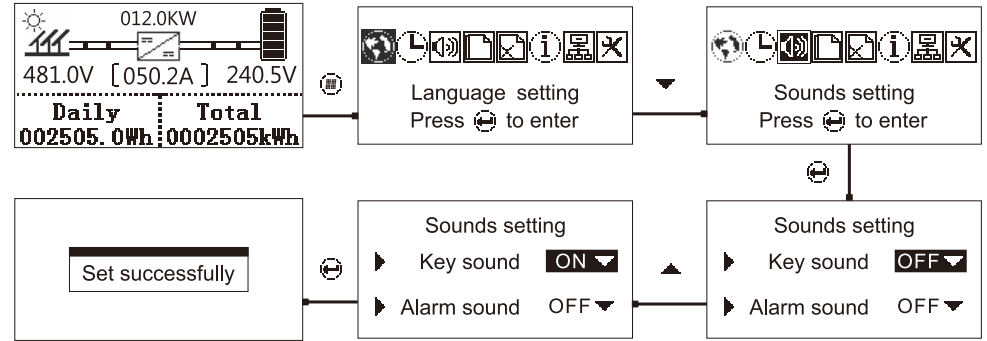

5.9 Records Query

In the default main interface, press MENU to enter the main menu, press DOWN to select record query, press ENTER to enter record query, press DOWN or UP to select the curve record query or fault record query, press ENTER to enter the curve record query or fault record query, press DOWN or UP to check the record and there are 10 records totally. Press MENU to return to the upper and main interface.

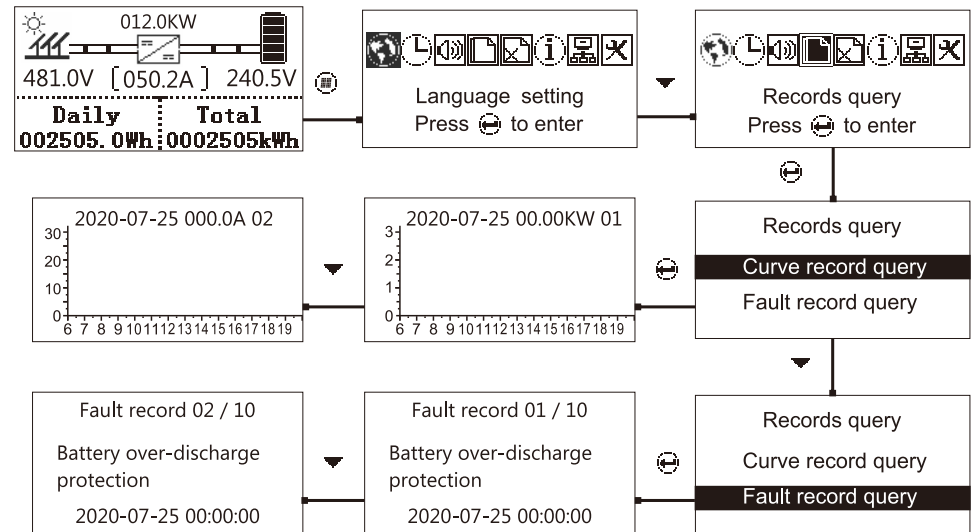

5.10 Delete Record

In the default main interface, press MENU to enter the main menu, press DOWN to select the delete record, press ENTER to enter the delete record, press DOWN to move the cursor, press UP to select whether to delete, press ENTER to delete after selecting and press MENU to return to the upper menu and main interface after hearing continuous indicative sound.

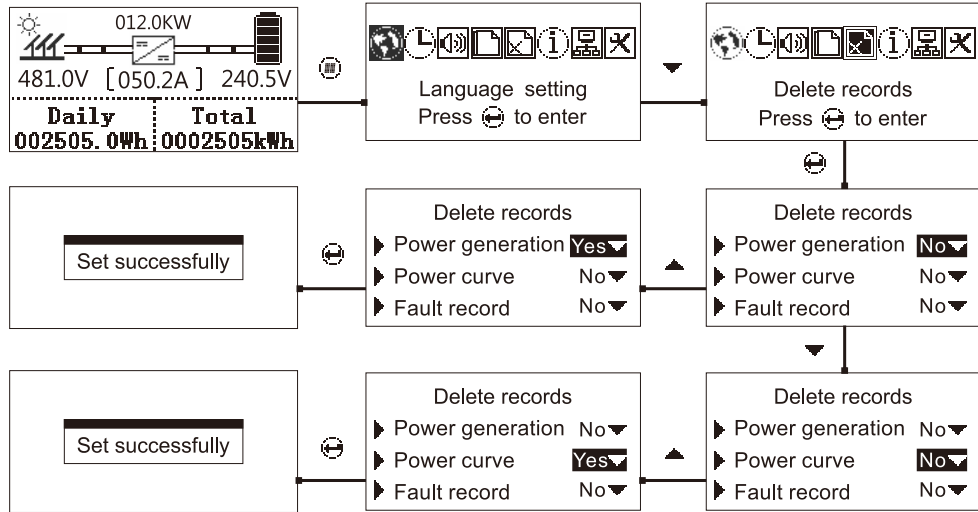

5.11 System Information

In the default main interface, press MENU to enter the main menu, press DOWN to select the system information, press ENTER to enter the system information, press MENU to return to the main interface.

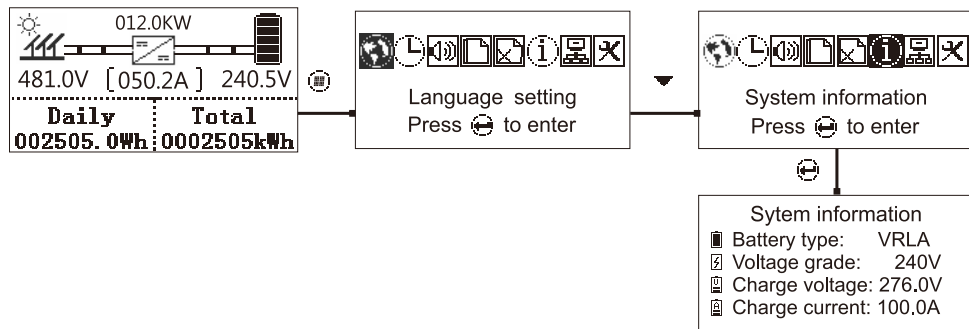

5.12 Communication Setting

In the default main interface, press MENU to enter the main menu, press DOWN to select the correspondence setting, press ENTER to enter the correspondence setting, press DOWN to select the baud rate setting or the local address setting, press UP to set Baud rate and the local address value, press ENTER to confirm and press MENU to return to the upper menu and main interface after hearing continuous indicative sound.

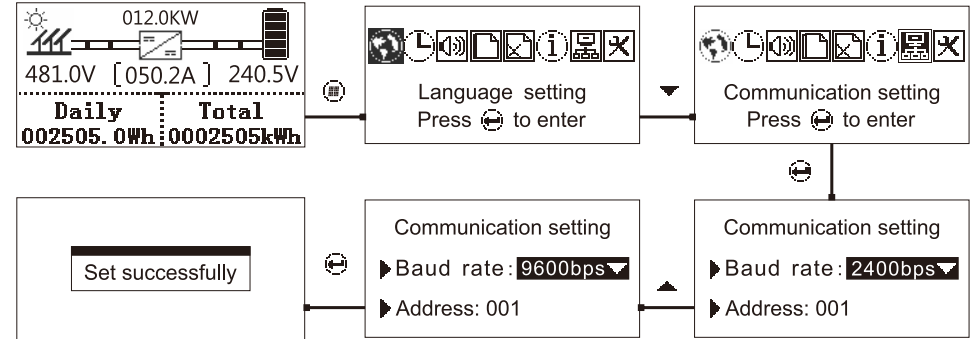

5.13 Parameter Settings

In the default main interface, press MENU to enter the main menu, press DOWN to select the operating parameter setting, press ENTER to enter the password prompt interface, enter the password and then press ENTER to enter the operating parameter setting.

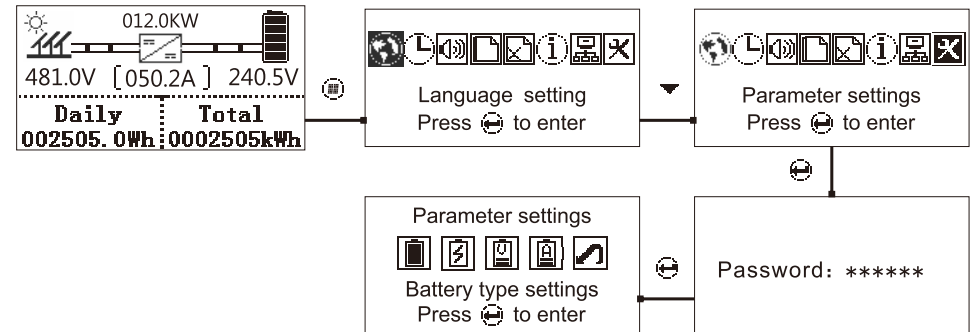

Note 1 Before setting the operating parameters, you must disconnect the circuit breaker which connects the PV module with the MPPT controller, set 5 parameters: battery type, rated voltage setting, charging voltage setting, charging current setting, discharging lower limit setting, check if parameters displayed on the system information are corresponding and then turned on the PV module circuit breaker

Note 2 The operating parameter setting must be operated by qualified technicians. The MPPT controller will not work or suffer from damage of battery due to wrong operation.

5.14 Battery type setting

In the operating parameters interface, press ENTER to enter the battery type setting, press UP to select battery type (Maintenance-free lead acid battery, colloidal battery, liquid battery, lithium series battery), press ENTER to confirm and press MENU to return to upper menu after hearing continuous indicative sound.

Note Factory setting defaults to maintenance-free lead acid.

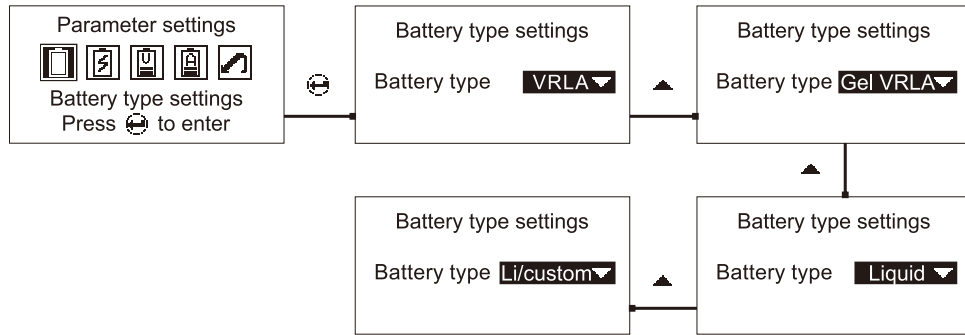

5.15 Battery Rated Voltage

In the operating parameters interface, press DOWN to select rated voltage setting, press ENTER to enter rated voltage setting interface, press UP to select voltage level(Adjustable, 192V, 216V, 240V), press ENTER to confirm and press MENU to return to upper menu after hearing continuous indicative sound.

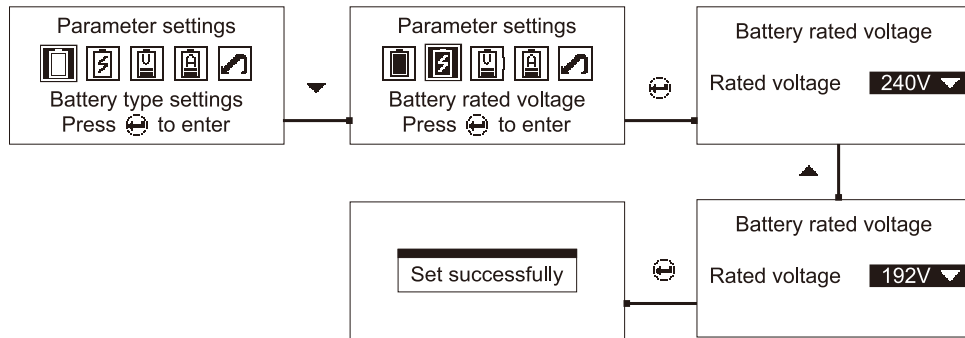

Note Factory setting defaults to automatically identify the level of rated voltage which can only identify lead acid battery but lithium series battery are not included. When automatically identify the level of rated voltage, charging voltage and discharging lower limit voltage setting are not available. Charging voltage and discharging lower limit voltage setting are only available for manual setting.

5.16 Charge Voltage Settings

In the operating parameters interface, press DOWN to select charging voltage setting, press ENTER to enter rated voltage setting interface, press DOWN to move cursor, press UP to input numeral, press ENTER to confirm and save and press MENU to return to upper menu after hearing continuous indicative sound.

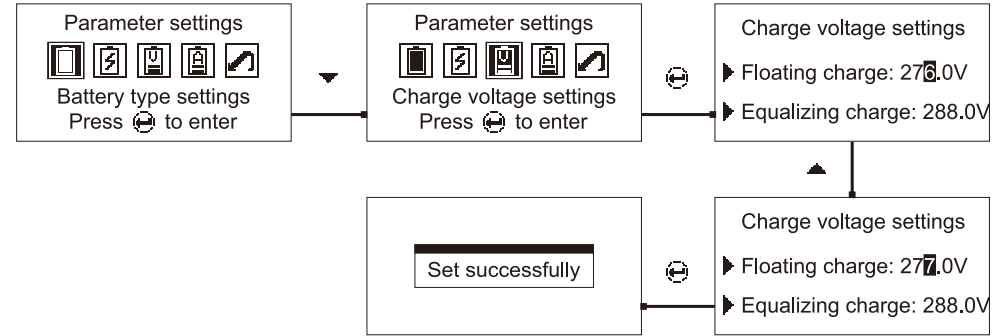

Note Lithium battery series only have float (constant voltage) charging mode. Equalized charging mode can be only used for lead acid battery.

5.17 Charge Current Settings

In the operating parameters interface, press DOWN to select charging current setting, press ENTER to enter charging current setting interface, press DOWN to move cursor, press UP to input value, press ENTER to confirm and save and press MENU to return to upper menu after hearing continuous indicative sound.

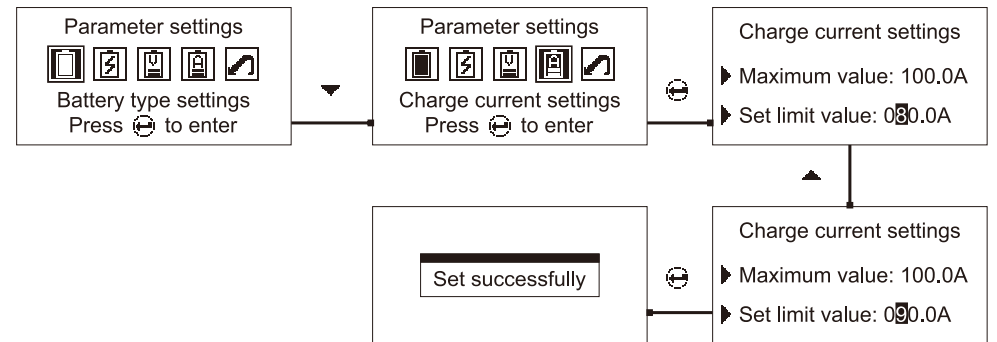

Note The set point can not be greater than the current maximum.

5.18 Restore factory settings

In the operating parameters interface, press DOWN to select factory reset, press ENTER to enter factory reset interface, press UP to select whether to restore factory setting, press ENTER to confirm and save and press MENU to return to upper menu after hearing continuous indicative sound.

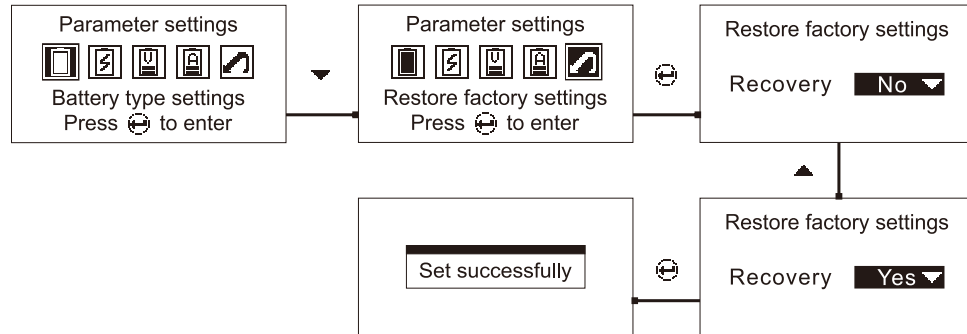

- i** When MPPT solar controller can not operate normally due to fault of operating parameter setting, please restore the operating parameters to factory setting.

The default password is : Press DOWN for 3 times and then UP for 3 times.

6. Technical Parameter

Model	100A	120A	150A	
Charging Mode	MPPT automatic maximum power point tracking			
Charging Method	Three stages: Constant current charging(MPPT),Equalizing charging, float charging			
System Type	192V/220V/240V/ 360V/384V	Optional		
System Identification Voltage Range	192V System	DC160V-DC240V		
	220V System	DC180V-DC270V		
	240V System	DC200V-DC300V		
	360V System	DC300V-DC450V		
	384V System	DC320V-DC480V		
Quiescent Dissipation	192V/220V/240V/ 360V/384V	≤10W		
Overall Unit Efficiency	192V/220V/240V/ 360V/384V	≥96.5%		
Photovoltaic Module Utilization Ratio	192V/220V/240V/ 360V/384V	≤99%		
Input Characteristics				
Mppt Working Voltage Range	192V System	DC240V-DC600V		
	220V System	DC270V-DC600V		
	240V System	DC300V-DC600V		
	360V System	DC450V-DC750V		
	384V System	DC450V-DC750V		
Maximum Solar Input Power	192V System	22400W	26880W	33600W
	220V System	25200W	30240W	37800W
	240V System	28000W	33600W	42000W
	360V System	42000W	50400W	63000W
	384V System	44800W	53760W	67200W

- i** Note:The above data is for reference,if there is any change,the actual product shall prevail.

Model	100A	120A	150A
Output Characteristics			
Optional Battery Type	192V/220V/240V/360V/384V	Lead-acid battery, lithium battery, gel battery or user-defined	
Charging Method	Floating Charging	Equalizing Charging	
Lead Acid Battery	192V System	220V	227V
	220V System	247.5V	255.6V
	240V System	275V	284V
	360V System	412.5V	426V
	384V System	440V	454V
Gel Battery	192V System	220.8V	230.4V
	220V System	248.4V	259.2V
	240V System	276V	288V
	360V System	414V	432V
	384V System	441.6V	460.8V
SLA	192V System	227.2V	230.4V
	220V System	258.6V	259.2V
	240V System	284V	288V
	360V System	428V	432V
	384V System	454.4V	460.8V
Floating Charging Voltage	192V/220V/240V	192V-300V(Adjustable)	
	360V/384V	384V-600V(Adjustable)	

i Note:The above data is for reference,if there is any change,the actual product shall prevail.

Model	100A	120A	150A	
Rated Current	192V/220V/240V/360V/384V	100A	120A	150A
Current-limiting Protection	192V/220V/240V/360V/384V	105A	125A	155A
Temperature Coefficient	192V/220V/240V/360V/384V	±0.02%/°C		
Auto Temperature Compensation	192V/220V/240V/360V/384V	-4mV°C		
Display				
LCD Display	LCD panel indicating solar power, load level, battery voltage/capacity, charging current, and fault conditions			
LED Display	Charge Indication, Fault Indication			
PC Uppon Computer (Communication port)	RS-485			
Protection				
Input Open Circuit Voltage	192V/220V/240V	≤650V		
	360V/384V	≤800V		
Input Low Voltage Protection	Reference Input Attribute			
Input High Voltage Protection	Reference Input Attribute			
Input Polarity Reverse Protection	Yes			
Output Polarity Reverse Protection	Yes			
High Temperature Protection	≥85°C			
Audible Noise	≤45dB			
Heat Dissipation Mode	Intelligent Air Cooling			

i Note:The above data is for reference,if there is any change,the actual product shall prevail.

Model	100A	120A	150A
Product Specification Package			
Product Size (L*W*H) mm	624x411x205		624x450x205
Net Weight (kg)	28.3		—
Type Of Mechanical Protection	IP32		
Environmental Requirements			
Humidity	0~90%RH (No Dew)		
Height Above Sea Level	0~3500m		
Ambient Temperature	-20°C~+50°C		
Storage Temperature	-40°C~+70°C		
Photovoltaic Module Configuration			
System Voltage (battery Voltage)	Photovoltaic Module Load Voltage (recommended Data)		
192V System	550V		
220V System			
240V System			
360V System	700V		
384V System			

i Note:The above data is for reference,if there is any change,the actual product shall prevail.

7. Fault Elimination

When the controller works abnormally,please check conditions listed as below

Fault Situation	Fault Elimination
When controller is electrified for the first time, fault prompts: battery voltage is out of normal range	<ol style="list-style-type: none"> 1.Check whether the battery voltage is in the range of system voltage identification (See technical parameters for system voltage identification range) 2.Manually set rated battery voltage level (See the rated battery voltage setting in the operating parameters setting)
Fault indication: over temperature protection	<ol style="list-style-type: none"> 1 .Check whether the cooling fan is damaged and ventilation vents are blocked by debris; MPPT controller should be installed in a ventilated environment 2.Reasonable PV module configuration can improve conversion efficiency and reduce temperature rise (technical parameters PV module configuration)
Fault indication: battery over discharging protection	The battery is out of power
Fault indication: can not test external temperature sensor	<ol style="list-style-type: none"> 1 Check whether it is connected to the external temperature sensor 2 check whether the sensor contact is bad
Charging indicative light and displays of charging current and charging power are off and on	<ol style="list-style-type: none"> 1 Check whether PV module voltage is in the MPPT operating voltage range. 2 Check whether the charging voltage parameters shown on system are correct. 3 Correct the charging voltage parameters or restore the factory settings to restart dynamic MPPT controller. 4 Check whether the fuse is broken and the circuit breaker is disconnected.
Charging indicative light is off and on alternatively; charging current appears alternatively	This situation generally appears in cloudy day or evening when the light is insufficient which is a normal phenomenon
No power curve and current curve display	Check whether the time and date of the MPPT controller are consistent with the time you are in.(see time and date set)

If the problem is still on the table, please contact customer service personnel : Please provide the following information: equipment: type, order number, serial number (the label on the back plate); a detailed description of the problem (such as the use of the type system, problems occurred occasionally or frequently, indicating light, display etc.).

8. Maintenance And Cleaning

8.1 Fuse Replacement

Fuse blown due to excessively high temperature or other faults needs correct replacement: pull out the broken fuse from the joint, install new fuse, check if it is connected correctly and then install equipment.(Fuse is near the connecting box)

8.2 Clean Fan Vent & Heat Sink

Please regularly clean fan vent and internal heat sink with dry or slightly wet cloth. Please pay attention that washing liquid or corrosive solvent are banned for cleaning and liquid is not allowed to flow into machine to make sure that the air vents are not blocked.

9. Quality Assurance

During the warranty period, our company will repair for free or replace with new products

Evidence

In the quality assurance period, our company requires customers to provide invoices and date of purchased products.

At the same time the trademark on the product should be clearly visible, otherwise we have the right not to guarantee quality.

Condition

The rejected products shall be disposed of by our company

The customer shall allow reasonable time to repair the faulty equipment

Exemption from liability

In the following cases, our company will be not responsible for repair:

The whole machine or spare parts are beyond the warranty period

Transport damage

Incorrect installation or modification

Operating in a very harsh environment described beyond this manual

Failure or damage to the machine caused by the service, repair, alteration or removal of our company

Abnormal natural environmental damage

If customers ask for amendment service due to problems caused by faults listed above, our company can provide compensable amendment service after judgment of our service constitute.

NOTE

The charge of product size and parameter is subject to the newest materials of our company without further notice.